

OPERATION

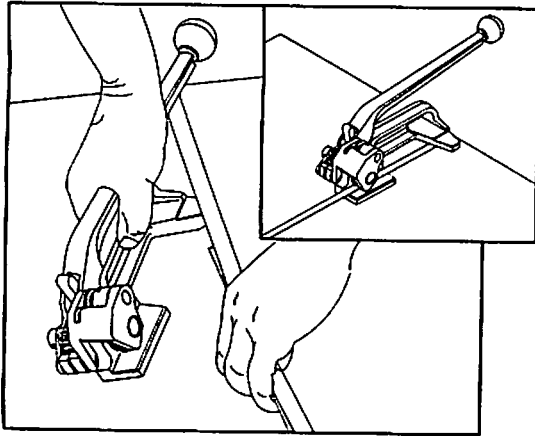

1. THREADING TOOL

Feed direct from the reel in front; loop the strap around the package with end of strap underneath. Hold strap in position with left hand, see above. With Tightening Handle (H54-002 or H55-002). in full rear position, grasp tool in right hand and squeeze Tightening and Base Handles together. This raises the tightening head to full open position for easy threading of tool. Slide rear foot of tool under strap, then swing tool to left so that strap is directly under Feedwheel (H54-006). Note, if package being strapped has narrow surface, strap should pass under rear foot--see insert; otherwise, strap passes over rear foot as shown in large illustration.

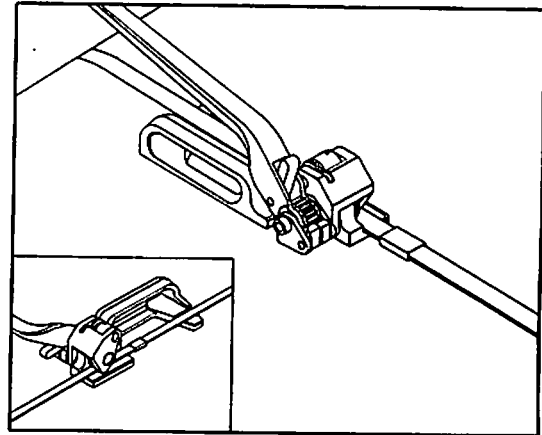

2. PLACING THE SEAL

For "front" sealing the lower strap should extend to the rear edge of the front foot. Snap-on (open) seals is placed against front of tool. See large illustration above. For "rear" sealing, lower strap should extend 2.5 CM (one inch) beyond rear edge of front foot as shown in insert illustration above. If, after desired tension is reached, the position of handle prevents easy use of sealer, press Handle pawl (H54-007) forward with thumb (see insert below)--This allows for repositioning of handle in any position. Sealer should be held with handles wide apart directly on center of seal.

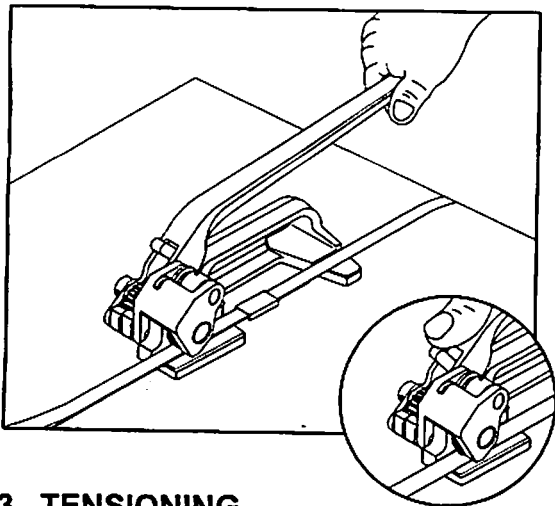

3. TENSIONING

Move Tightening Handle to extreme rear position as this automatically releases tension. To obtain maximum leverage at the most convenient position, press Handle Pawl forward with thumb and reposition handle. See insert above.

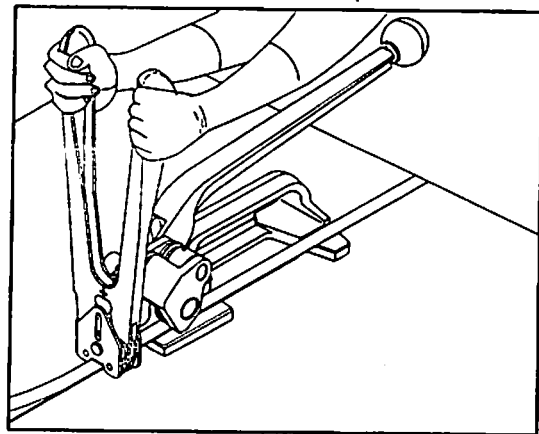

4. SEALING

For fast front sealing, nose of tool is rounded so that it may be used to guide sealer to correct position. Bring sealer handles to closed position crimps seal. Tension will hold tool in position while seal is crimped.

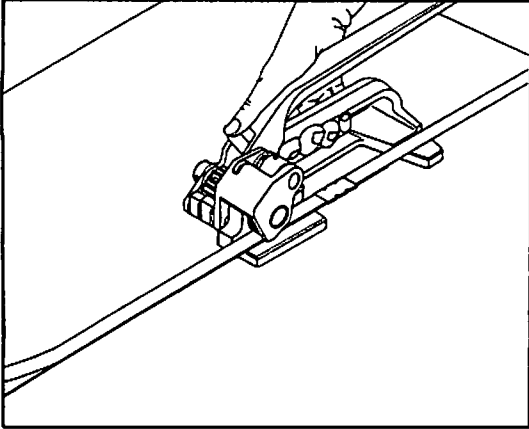

5. REPOSTTIONING TIGHTENING HANDLE

Push Handle Pawl forward. This drops Tightening Handle against Base Handle.

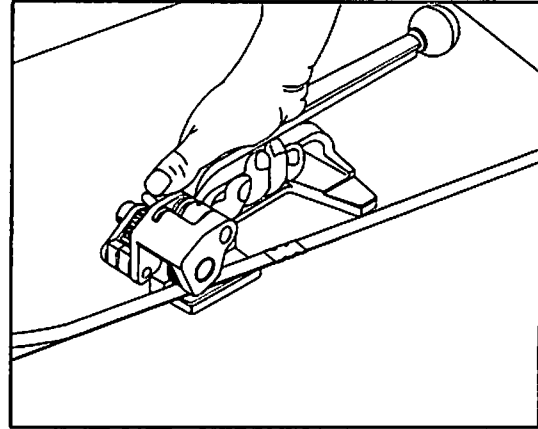

6. STRIPPING TOOL

Squeeze Tightening Handle against Base Handle to raise tightening head to full open position. Remove tool with quick sliding motion to the right as shown in above photo.

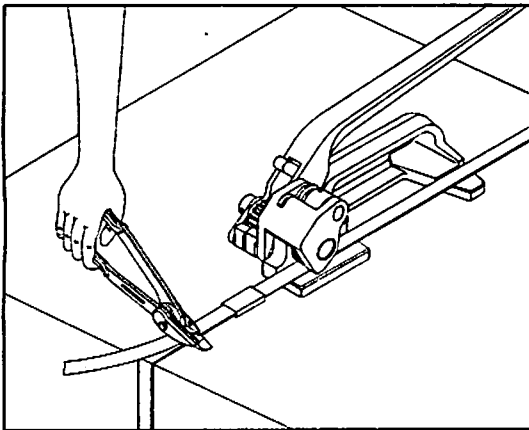

7. CUTTING THE STRAP

Cut the strap off cleanly at seal by using the cutter.

MAINTENANCE INSTRUCTIONS

- KEEP TOOL CLEAN BY BRUSHING OR PERIODICALLY BLOWING DUST OR DIRT OFF WITH CLEAN, DRY COMPRESSED AIR.
- PERIODICALLY LUBRICATE ALL MOVING PARTS WITH ONE OR TWO DROPS OF LIGHT MACHINE OIL.